

Technology for Simultaneous Production of US Grade Gasoline and High Purity Benzene from FCC C6 Heart Cut Naphtha

Introduction

The MSAT – II regulations which became active on January 1, 2011 (“EPA Regulatory Announcement” – EPA420-F-07-017, February 2007), restricts the average benzene level in Gasoline sold in U.S (except California), to 0.62 % vol. Another driving force behind this technology is the conversion of conventional Naphtha Crackers to Gas Crackers due to availability of low cost feedstocks like shale gas. A light naphtha cracker produces nearly 10 times the amount of PyGas – which can be converted into aromatics – than an ethane cracker. This ongoing shift to lighter feedstocks can have a significant negative impact on heavier co-products such as aromatics, with yields cut by as much as 55%.

Currently Fluid Catalytic Cracker (FCC) gasoline or FCC Naphtha comprises nearly 10-20 % of the gasoline pool in a typical refinery. Full range FCC gasoline contains around 15-30 vol. % aromatics with up to 2 vol. % benzene and 1000 – 2000 ppm sulfur. A narrow C6 heart cut fraction of the full range gasoline will contain anywhere between 11 – 19 wt. % benzene and up to 500 ppm sulfur.

Hydro-processing routes for benzene and sulfur reduction in FCC Gasoline results in olefin saturation thus lowering the octane. Unprocessed FCC Gasoline contains reactive impurities like oxygenates, metals, chlorides, sulphur compounds, nitrogen compounds, di-olefins and organic peroxides. Due to the complex nature of this feedstock, an economic and reliable benzene removal process is difficult to develop and has not been practiced in the industry so far.

This technology serves a dual role of recovering high purity benzene (>97 wt. % pure) and producing environmental friendly gasoline (Bz. < 0.4 wt. %) from FCC C6 heart cut stream using extractive distillation without the requirement of a prior-hydrogenation or pre-processing step to saturate di-olefins in feedstock and reduce impurities. The technology has been successfully commercialized in RIL Jamnagar. It is an excellent example of Industry – Academia collaboration in successful implementation of a technology for the benefit of not only the contributing partners but for the Nation as a whole.

Important Parameters unique to the Development

- ❖ First of its kind technology in the world
- ❖ Fully indigenous technology
- ❖ Low CAPEX and OPEX compared to other existing technologies worldwide for benzene/ aromatics recovery
- ❖ Solvent system is highly stable (thermally and chemically)
- ❖ Can process impurity laden feedstock without requirement of any pre-processing step
- ❖ Fully automated and reliable design
- ❖ With increase in Propylene demand FCCU severity is increasing which results in more benzene in FCC gasoline. Thus there is high probability to license these unit within/ outside India to Refiners who want to make quality gasoline & recover benzene as product

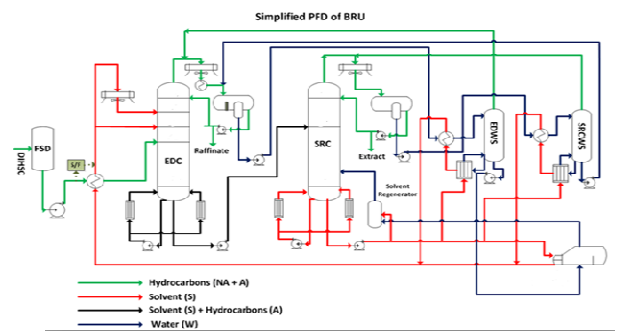

Simplified Process Flow Diagram

Major Application(s)

Major application of the technology will be for the production of benzene lean gasoline from FCC Naphtha. The by-product of the process, benzene rich aromatics stream may be further purified in downstream fractionation units to get high purity benzene. The technology will soon become the need of the hour, in view of not only producing clean sulfur and benzene lean gasoline but also for efficient recovery of high value materials (like benzene) from alternative feedstocks such as FCC naphtha.



Benzene Recovery Unit RIL Jamnagar

General impact, highlighting the societal impact, if any

- ❖ Direct Employment: ~28-30 Lakh Man Hours in R&D, Engineering, Construction, etc.
- ❖ Indirect Employment: ~10-12 Lakh Man Hours in Fabrication of Equipment and Steel
- ❖ Mobile Sources Air Toxics (MSAT) emission will reduce by ~25% vol.
- ❖ FCC gasoline comprises nearly 10-20 % of the gasoline pool in a typical refinery hence with this technology Gasoline will contain ~20% less benzene overall.
- ❖ New passenger vehicle and portable gasoline containers will emit less benzene
- ❖ Lower PM emissions will result in less premature deaths annually
- ❖ Reduced exposure to Benzene will result in lower health treatment cost



CSIR Technology Award for Innovation – 2014 & ICC Award for Excellence in Process Design – 2016

Status of Development

- ❖ A 0.6 MMTPA Benzene Recovery unit based on this technology has been successfully commissioned in RIL Jamnagar in May 2016 under the J3 Expansion project
- ❖ Total expenditure incurred till commercialization : ~ Rs. 300 Crore INR
- ❖ Expenditure incurred on R&D : ~ 3.0 Crore INR
- ❖ Year wise profitability : ~ 43 Million USD/ ~ 282 Crore INR per annum
- ❖ Payback period at current price: ~1.1 Years
- ❖ Granted Patent in India, US, China, Europe, Russia, Spain, and Japan



Plant Commissioning in May 2016 at RIL Jamnagar

